



## Features

- 1.- Full port minimizes pressure drop and prolong life.
- 2.- Locking device.
- 3.- Glass fiber reinforced PTFE seats.
- 4.- Adjustable stem packing.
- 5.- BLOW-OUT stem proof.
- 6.- Investment cast body construction.

## Design

- 7.- 1000# WOG from 1/4" - 1 1/2".
- 8.- 800# WOG from 2" - 3".
- 9.- Threaded NPT ends ANSI B 1.20.1.
- 10.- Manufactured in ISO 9001 approved facility.

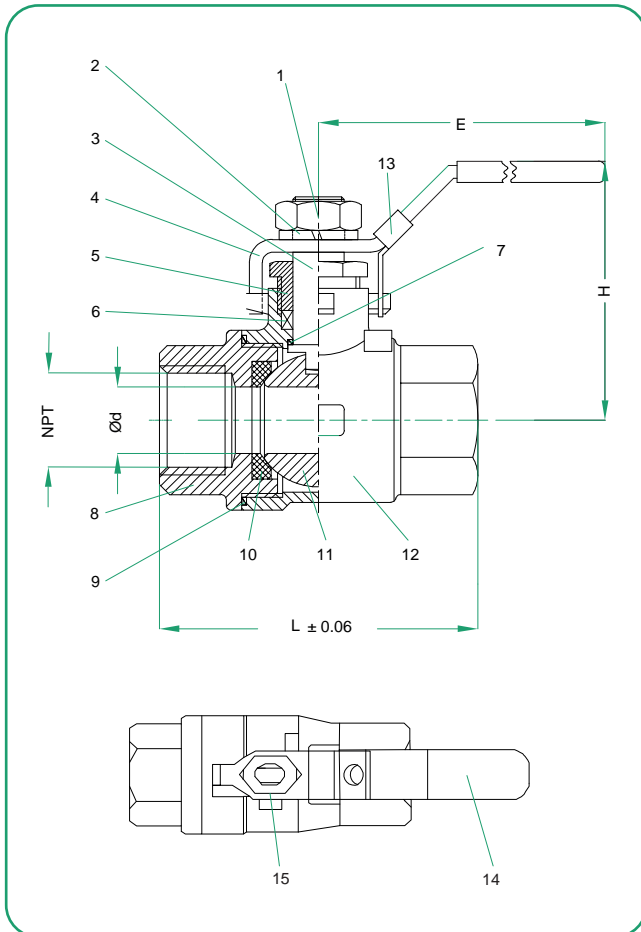

## Material List

POS	DESCRIPTION	CARBON STEEL	STAINLESS STEEL
		OPTION	OPTION
1	NUT	ASTM A192 2HM	ASTM A194 8M
2	SPRING WASHER	AISI 304	AISI 304
3	STEM	ASTM A182 F316	ASTM A182 F316
4	HANDLE	AISI 201	AISI 201
5	GLAND	ASTM A182 F304	ASTM A182 F304
6	PACKING	PTFE	PTFE
7	THRUST GASKET	PTFE	PTFE
8	CAP	ASTM A216 WCB	ASTM A351 CF8M
9	WASHER	STAINLESS STEEL	STAINLESS STEEL
10	SEAT	PTFE	PTFE
11	BALL	ASTM A182 F316	ASTM A182 F316
12	BODY	ASTM A216 WCB	ASTM A351 CF8M
13	LOCKING DEVICE	AISI 201	AISI 201
14	HANDLE SLEEVE	VYNIL	VYNIL
15	NUT	SS304	SS304



## Dimensions (inches)

NPS	Ød (in)	L (in)	H (in)	E (in)	NTP (in)	CV (USgal/min)	TORQUE (lb*in)	WEIGHT (lb)
1/4"	0.315	2.047	2.165	3.543	1/4"	2.00	30.980	0.44
3/8"	0.394	2.047	2.165	3.543	3/8"	2.00	30.980	0.44
1/2"	0.591	2.165	2.165	4.134	1/2"	3.30	39.830	0.51
3/4"	0.787	2.559	2.559	4.724	3/4"	7.07	61.960	0.75
1"	0.984	2.835	2.756	4.724	1"	12.25	75.230	1.19
1 1/4"	1.260	3.268	2.953	5.709	1 1/4"	20.60	128.34	1.84
1 1/2"	1.496	3.740	3.543	6.89	1 1/2"	28.30	185.87	2.43
2"	1.929	4.331	3.937	6.89	2"	47.04	247.82	3.64
2 1/2"	2.559	5.669	5.118	8.268	2 1/2"	107.33	761.16	11.13
3"	3.150	6.693	5.512	9.055	3"	196.45	1070.94	20.5

## Pressure-Temperature Chart

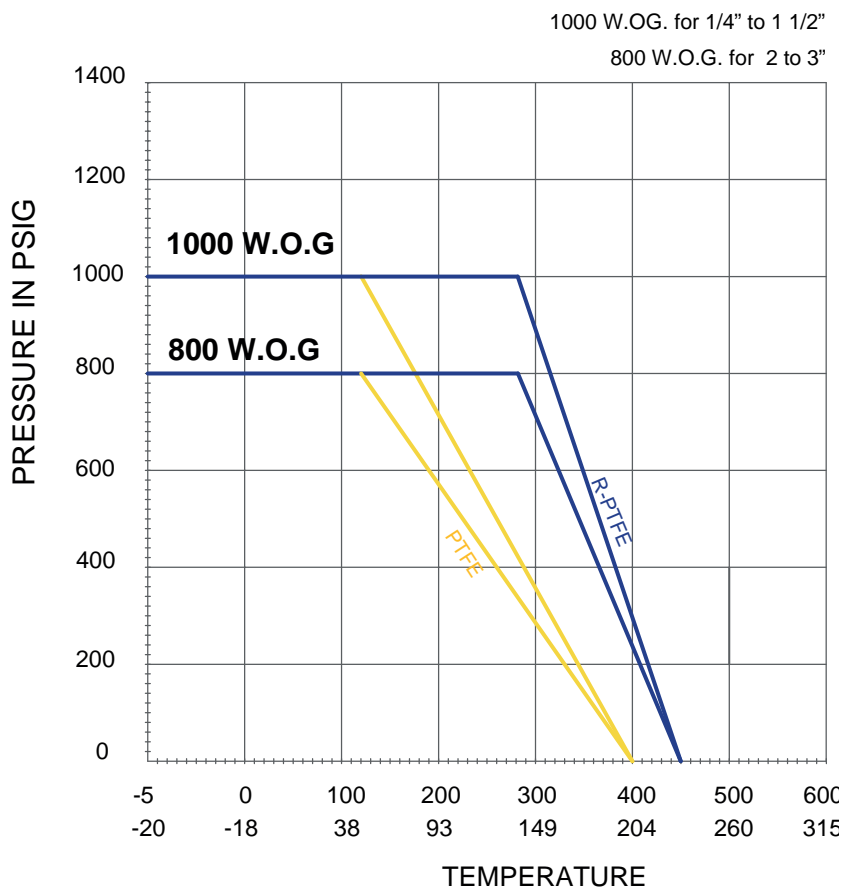

## How to Order

CLASS	VALVE BODY DESIGN (SERIES)	MATERIAL			ENDS	SIZE		OPERATION
		BODY	TRIM	SEAT				
1 800/1000# WOG <sup>(1)</sup>	2Z Economic Full Port Ball Valve 2 Pcs Compact Design	2 WCB	3 316 SS	P PTFE	T Threaded	0.25	1/4"	L Manual Lever Operator
		3 CF8M	4 304 SS	R R-PTFE		0.38	3/8"	
						0.5	1/2"	C Manual Lever with Locking Device
						0.75	3/4"	
						01	1"	
						01.25	1 1/4"	
						01.5	1 1/2"	
						02	2"	
						02.5	2 1/2"	
						03	3"	

### Example:

Economic Full Port Ball Valve Body & Trim 316SS, Seats: PTFE, Ends: Threaded, 1/2" 1000# WOG with Lever.

**12Z33PT0.5L**

NOTE:  
(1) 1000# WOG from 1/4" - 1 1/2", 800# WOG from 2" - 3".

