

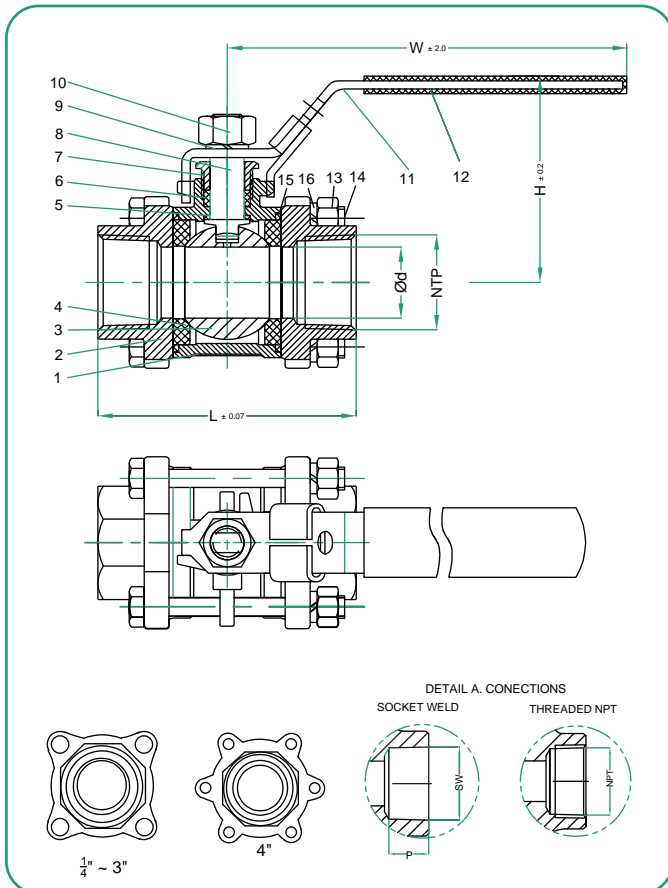

Features / Design

- 1.- Full port minimizes pressure drop and prolong life.
- 2.- Locking device.
- 3.- Glass fiber reinforced PTFE seats.
- 4.- Packing "V" ring design.
- 5.- Adjustable stem packing.
- 6.- Blow-Out stem proof.
- 7.- Investment cast body construction.
- 8.- 1000 PSI W.O.G.
- 9.- Threaded ends ANSI B1.20.1.
- 10.- Socket weld ends ANSI B16.11.
- 11.- Butt weld ends ANSI B16.25.
- 12.- Manufactured in ISO 9001 approved facility.
- 13.- Inspection and testing according to API598.



Material List

POS	DESCRIPTION	MATERIAL
1	BODY	A216 WCB / A351 CF8M
2	CAP	A216 WCB / A351 CF8M
3	BALL	ASTM A182 F316
4	SEAT	PTFE
5	THRUST WASHER	PTFE
6	PACKING	PTFE
7	GLAND BUSH	ASTM A276 F304
8	STEM	ASTM A276 F316
9	WASHER	STAINLESS STEEL
10	NUT	A192 2HM / A194 8M
11	HANDLE	STAINLESS STEEL
12	HANDLE COVER	PVC
13	NUT	A192 2HM / A194 8M
14	BOLT	A193 B7M / A193 B8M
15	JOIN GASKET	PTFE
16	WASHER	STAINLESS STEEL

*OTHER TRIMS AVAILABLE UPON REQUEST.

Dimensions (inches)

NPS (in)	d (in)	L ⁽¹⁾ (in)	H (in)	W (in)	NPT (in)	SW (in)	P (in)	CV (USgal/min)	TORQUE (Lbf*in)	WEIGHT (lb) NOTE6
1/4"	0.394	2.677	2.126	3.858	1/4"	0.567 ± 0.008	0.374	6.00	6.00	/
3/8"	0.492	2.677	2.126	3.858	3/8"	0.700 ± 0.008	0.374	7.00	6.00	/
1/2"	0.591	2.874	2.520	3.937	1/2"	0.866 ± 0.008	0.374	10.000	8.000	4.94
3/4"	0.787	3.307	2.717	4.724	3/4"	1.078 ± 0.008	0.492	25.00	10.00	6.61
1"	0.984	3.583	2.874	5.433	1"	1.342 ± 0.008	0.492	35.00	15.00	9.26
1 1/4"	1.260	4.409	3.110	6.496	1 1/4"	1.689 ± 0.008	0.492	46.00	18.00	13.45
1 1/2"	1.496	4.724	3.583	7.087	1 1/2"	1.929 ± 0.008	0.492	80.00	24.00	15.87
2"	1.969	5.827	3.976	7.087	2"	2.419 ± 0.008	0.629	110.00	30.00	23.15
2 1/2"	2.559	7.087	5.000	9.843	2 1/2"	2.919 ± 0.01	0.629	310.00	50.00	34.83
3"	3.150	8.071	5.433	9.843	3"	3.545 ± 0.01	0.629	360.00	60.00	49.60
4"	3.937	10.472	7.874	14.449	4"	4.545 ± 0.01	0.629	820.00	100.00	88.18

NOTE:
(1) Face to face for threaded NPT and socketweld valves.

Pressure-Temperature Chart

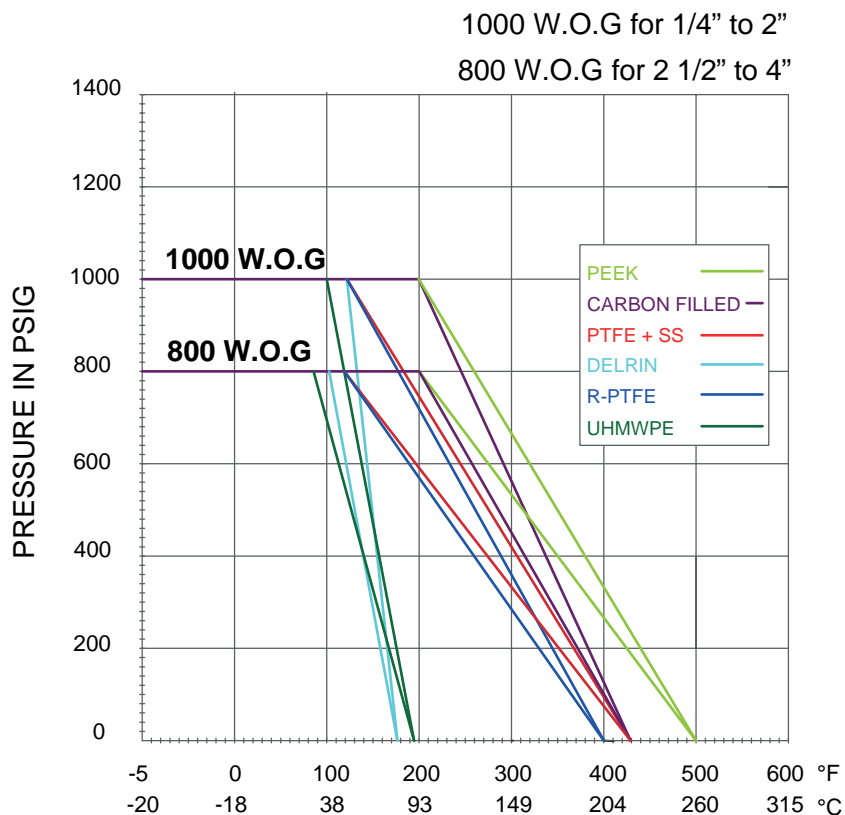

How to Order

CLASS	VALVE BODY DESIGN (SERIES)	SPECIAL FEATURES		MATERIAL			ENDS	SIZE		OPERATION					
				BODY	TRIM	SEAT									
1 800/1000# WOG ⁽¹⁾	3 Full Port 3 Pcs Ball Valve	NONE	NONE	2	WCB	3	316 SS	P	PTFE	T	Threaded	0.25	1/4"	L	Manual Lever Operator
				3	CF8M	4	304 SS	R	R-PTFE	M	Two different ends to be specify on each order	0.38	3/8"	C	Manual Lever with Locking Device
								U	UHMWPE			0.5	1/2"		
									50/50 SS	S	Socket Weld	0.75	3/4"		
									Filled PTFE	S	Butt Weld	01	1"	O	Oval Handle
									Carbon Filled PTFE	B	Flanged RF (150#)	01.25	1 1/4"	S	Spring Return safety Handle
									MG1241	F		01.5	1 1/2"	SR	Spring Return Sliding lock
									DELTRIN			02	2"		
									PEEK			02.5	2 1/2"	X	Economical Stem extention
									NBR			03	3"		
												04	4"	B	Bare Shaft
														P	Preumatic Actuator
														E	Electric Actuator

Example:

Full Port Ball Valve, Body WCB, Trim 316SS, Seats: R-PTFE, Ends: Threaded, Size 1/2", 1000# WOG with Lever.

1323RT0.5L

NOTE:
(1) 1000# WOG from 1/4" - 2", 800# WOG from 2 1/2" - 4".

