

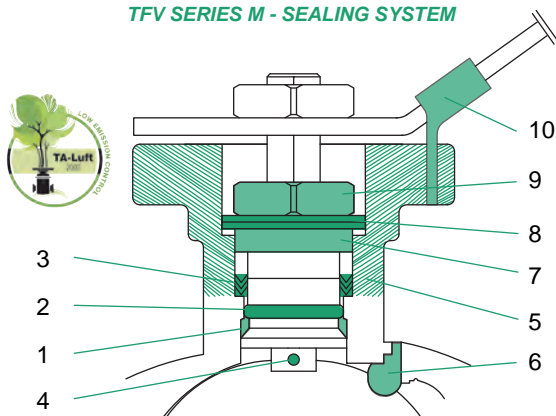

## Features / Design

- 1.- **Direct Mount High Performance Multi Port 3-Way Ball Valve** – “L”Port / “T” Port.
- 2.- **Cost Efficient.** One valve can replace two or more valves, reduces the number of valves in piping system.
- 3.- **Semi-Trunnion Ball Design.**
- 4.- **Five Entry Construction.**
- 5.- **Five Seats design.** Design for equal seat loading and positive sealing at any port.
- 6.- **Full port,** minimizes pressure drop and prolong life.
- 7.- Investment cast body construction for 1/4” to 3”; body sand cast & ends investment cast for 4”.
- 8.- **Pressure Rating:** 1,000 PSI (1/4” to 1”), 800 PSI (1-1/4” to 2”), 600 PSI (2-1/2” to 3”) and 300 PSI (for 4”).
- 9.- **Patented ISO 5211 Direct Mount Pad** allows direct mounting of pneumatic and electric actuators (no brackets and coupling are required).
- 10.- **Easy and Low Cost** for automated service and extremely high cycle life.
- 11.- **TFV Triple – Sealing Stem (High Cycle) Stem Packing System** – live loaded maintenance free – extra long cycle life (100,000 cycles and up).– TA-Luft approved.
  - Primary Seal** Pyramidal stem with stem seal.
  - Secondary Seal** Chevron “V” Ring design improves seal and reduce actuation torque.
  - Self Adjusting Stem Packing System with Belleville Washers** (automatically adjust wear temperature and pressure fluctuations).
- 12.- **Anti-Static Device** (ball to stem) as standard & Blow-Out proof stem.
- 13.- Wide range of valve (body) and seat materials available.
  - For valve: ASTM A351 Gr. CF8M, WCB, CF3M... and others.
  - Seats: PTFE, RPTFE, TFM 1600, Carbon Filled PTFE, 50/50 SS Filled PTFE, UHMWPE... and others.
- 14.- Inspection and testing according to API 598.
- 15.- NACE MR0175 (upon request).
- 16.- End connection: Threaded (NPT) ASME B1.20.1, Socket Weld (SW) ASME B16.11.
- 17.- Manufactured in ISO 9001 approved facility.

### TFV SERIES M - SEALING SYSTEM



1. **Piramidal Primary Seal.** Transform the vertical forces to horizontal forces at 360° of stem.
2. **Secondary Seal.** O’Ring Seal located between the primary and secondary seals.
3. **Tertiary Type Chevron Seal.** These seals are under constant expansion to make contact with the stem and the stuffing box.
4. **Static Loads Eliminator.** Ball to stem anti-static device as standard; the stem to body anti-static device is optional.
5. **Direct Mount ISO 5211.** Coupling part-turn actuators (Part-turn) in industrial valves. Avoid using couplings and mounting plates.
6. **Seat & Seal.** Available in multiple materials for different applications.
7. Static charge distribution ring.
8. Live Loadings. Automatic adjustment against fluctuations in temperature, pressure and wear.
9. Anti-rotation security device.
10. Security Locking Lever avoid unnecessary return of the lever providing security in its operation.

## Material List

NO.	DESCRIPTION	MATERIAL
1	BODY	A216 WCB / A351 CF8M
2	END CAP-A	A216 WCB / A351 CF8M
3	END CAP-B	A216 WCB / A351 CF8M
4	SEAT RETAINER	A216 WCB / A351 CF8M
5	BALL	1/4"-1/2" ASTM A276 SS316 3/4"-4" ASTM 351 Gr. CF8M
6	SEAT	R-PTFE
7	JOIN GASKET	PTFE
8	STEM SEAL	R-PTFE
9	STEM	ASTM A276 SS316
10	STEM PACKING	25% GLASS FIBER FI LLED + PTFE
11	GLAND	AISI304
12	BELLEVILLE WASHER	AISI304
13	LOCK SADDLE	AISI304
14	STEM NUT	AISI304
15	STEM WASHER	AISI304
16	RETAINER SEAL	PTFE
17	HANDLE	AISI304
18	HANDLE SLEEVE	VINYL
19	LOCKING DEVICE	AISI304
20	BOLT NUT	ASTM A194 8
21	PIN NUT	AISI304
22	STOP PIN	AISI304
23	O-RING	VITON
24	WASHER	AISI304
25	ANTISTATIC DEVICE	SS304
26	STOP PIN	AISI316
27	HANDLE SCREW	AISI304
28	HANDLE BOLT	AISI304
29	WASHER	AISI304
30	HANDLE BUSH	AISI304
31	HANDLE-A	AISI304
32	HANDLE-B	AISI304
33	POSITION INDICATION	AISI304

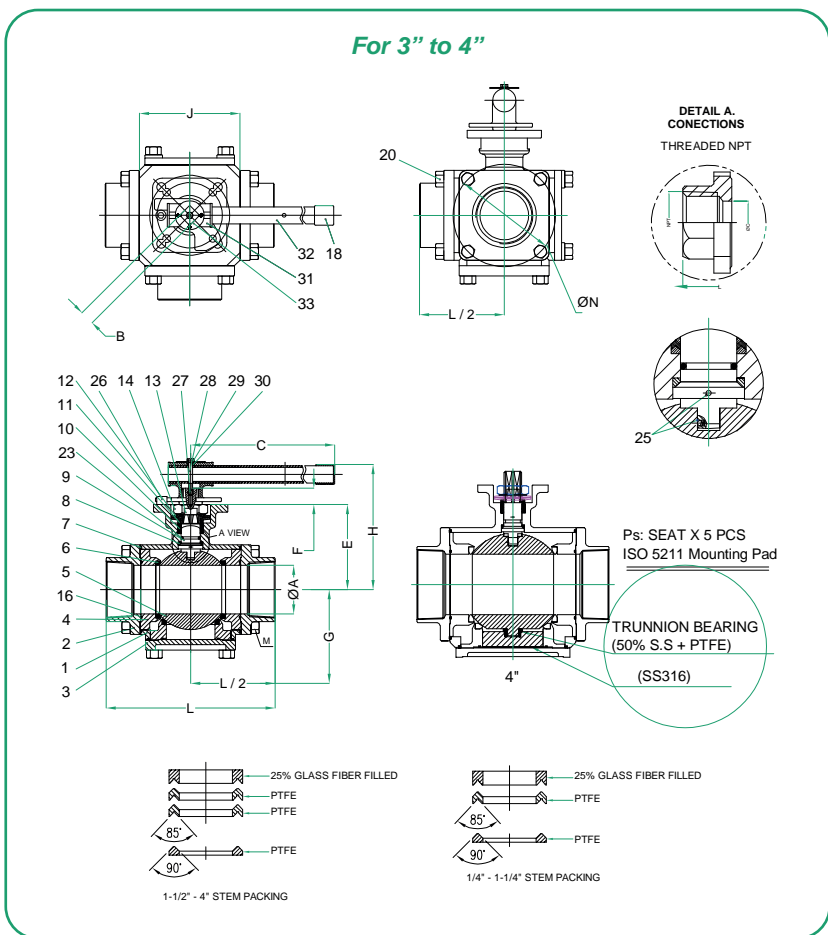
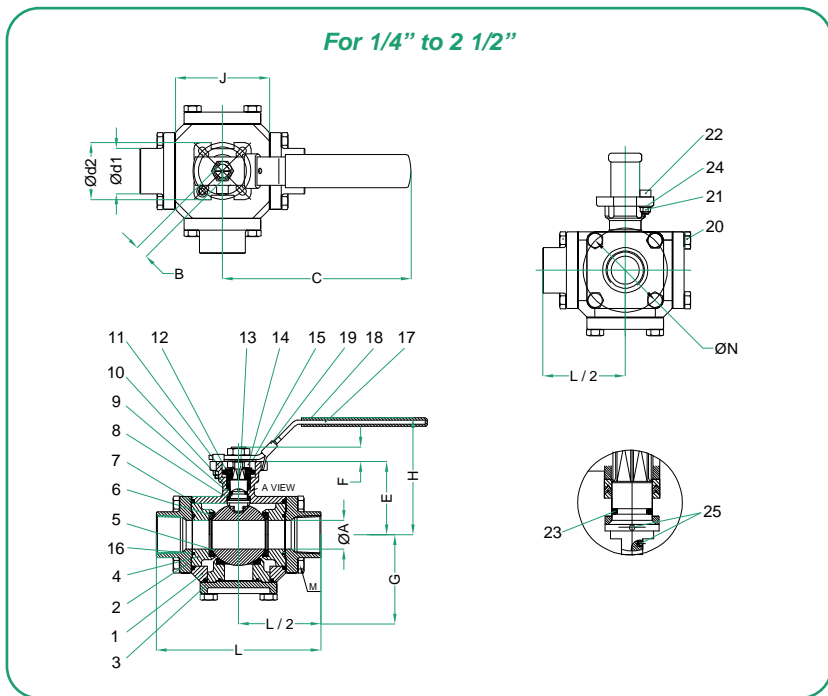

## FLOW STANDARD CONFIGURATION <sup>(1)</sup>

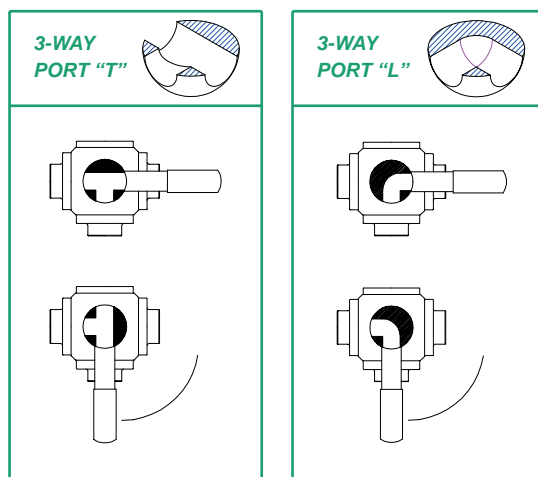

## Dimensions (inches)

SIZE	ØA (in)	B (in)	C (in)	E (in)	F (in)	G (in)	H (in)	J (in)	L (in)	M (in)	ØN (in)	Ød1 (in)	Ød2 (in)	ISO 5211	WEIGHT (Lb)	CV (US gpm)		Torque (lb*in) PTFE/RPTFE
																Port L	Port T	
1/4"	0.457	0.354	5.906	1.728	0.354	1.382	3.346	1.992	3.622	M6	1.772	1.417	1.654	F03/F04	/	7	15	81.0
3/8"	0.500	0.354	5.906	1.728	0.354	1.382	3.346	1.992	3.622	M6	1.772	1.417	1.654	F03/F04	/	7	15	81.0
1/2"	0.591	0.354	*	1.728	0.354	1.382	3.346	1.992	3.622	M6	1.772	1.378	1.654	F03/F04	2.866	13	25	81.0
3/4"	0.787	0.433	6.496	2.134	0.413	1.783	3.661	2.638	4.331	M6	2.323	1.654	1.969	F04/F05	6.195	23	46	151.0
1"	0.984	0.433	7.087	2.524	0.413	2.236	4.252	3.268	5.669	M8	2.913	1.654	1.969	F04/F05	10.494	35	70	257.0
1 1/4"	1.260	0.551	8.465	3.091	0.512	2.354	5.000	3.504	5.748	M8	3.268	1.969	2.756	F05/F07	/	54	109	310.0
1 1/2"	1.496	0.669	10.354	3.736	0.709	2.846	5.984	4.291	6.457	M10	3.976	2.756	4.016	F07/F10	23.281	81	162	523.0
2"	1.969	0.669	12.323	4.000	0.709	3.169	6.260	4.764	7.244	M12	4.567	2.756	4.016	F07/F10	29.586	153	309	638.0
2 1/2"	2.559	0.669	13.543	4.724	0.709	3.811	6.969	5.748	8.976	M14	5.591	2.756	4.016	F07/F10	/	186	376	815.0
3"	2.992	0.866	14.567	5.232	0.906	4.134	7.677	6.220	10.433	M16	6.299	/	/	F10/F12	63.603	290	589	1754.0
4"	3.937	0.866	20.079	6.457	0.906	5.177	8.898	8.228	12.480	M20	8.110	/	/	F10/F12	126.788	466	941	2215.0

## Pressure-Temperature Chart

1000 W.O.G for 1/4" to 1"  
800 W.O.G for 1 1/4" to 2"  
600 W.O.G for 2 1/2" to 3"  
300 W.O.G for 3" to 4"

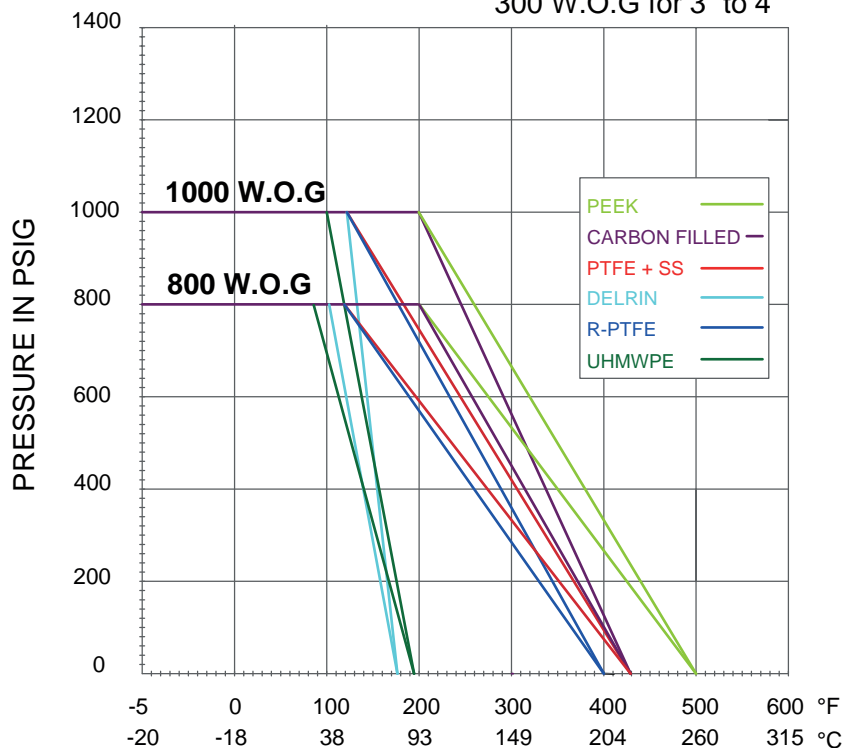

## How to Order

CLASS	VALVE BODY DESIGN (SERIES)		SPECIAL FEATURES		MATERIAL			ENDS	SIZE	OPERATION						
					BODY	TRIM	SEAT									
1 1000# WOG <sup>(2)</sup>	3WLM	Full Port 3 Ways Ball Valve Port "L" ISO 5211 MK	NONE	NONE	2	WCB	3	316 SS	P	PTFE	T	Threaded	0.25	1/4"	L	Manual Lever Operator
					3	CF8M			R	R-PTFE	S	Socket Weld	0.38	3/8"	C	Manual Lever with Locking Device
									C	Carbon Filled PTFE			0.5	1/2"		
									S	50/50 SS Filled PTFE			0.75	3/4"	B	Bare Shaft
									U	UHMWPE			01	1"	S	Spring Return Safety Handle
	3WTM	Full Port 3 Ways Ball Valve Port "T" ISO 5211 MK	O	Oxygen Service <sup>(3)</sup>					M	MG1241			01.25	1 1/4"	SR	Spring Return Sliding Lock
											02	2"	O	Oval Handle		
											02.5	2 1/2"	P	Pneumatic Actuator		
											03	3"	E	Electric Actuator		
											04	4"				

### Example:

3 Ways Full Port Ball Valve Port "L", ISO 5211 MK, Body & Trim 316SS, Seats: R-PTFE, Ends: Threaded, Size 1", 1000# WOG with Lever.

**13WML33RT01L**

NOTES:

- (1) Other flow pattern configurations available upon request.
- (2) Pressure Rating: 1,000 PSI (1/4" to 1"), 800 PSI (1-1/4" to 2"), 600 PSI (2-1/2" to 3") and 300 PSI (for 4").
- (3) Available for stainless steel valves only.

