

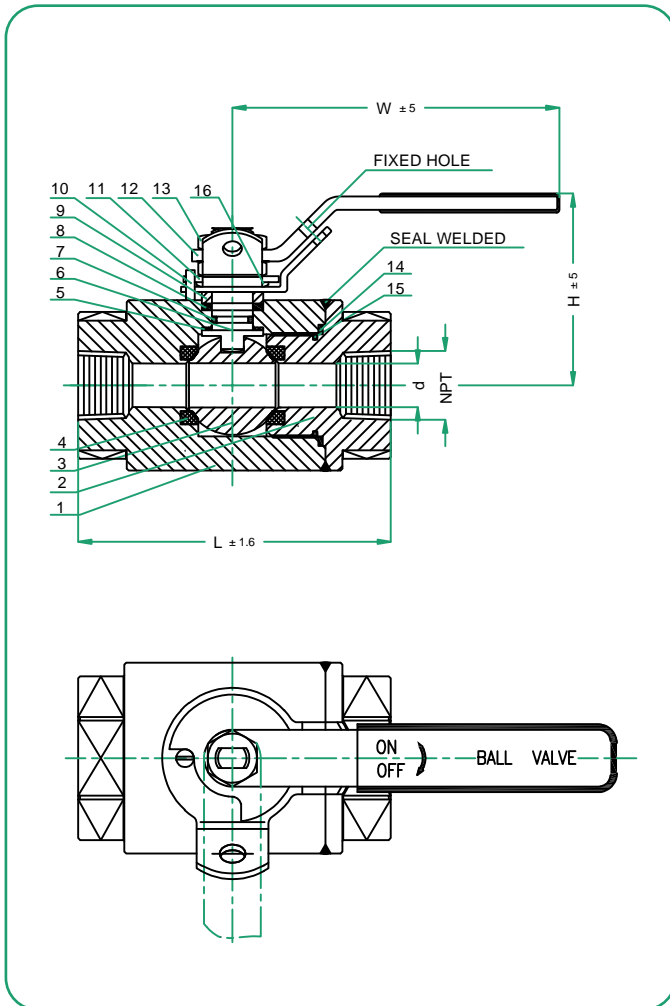

Features / Design

Forged Ball Valves / Seal Welded Body - 152W Series

- Full Port minimizes pressure drop and prolongs life.
- Forged Steel body construction (two pieces design).
- Seal Welded Body Design.
- Threaded NPT Ends ANSI B1.20.1.
- Socket Weld Ends ANSI B16.11 option available.
- ANSI Class 1500#.
- Manufactured in ISO 9001 approved facility.
- Design according API 608, ASME B16.34.
- Fire Safe API 607 (upon request).
- Hydrostatic Tests according API 598 & API 6D.
- NACE MR0175 (upon request).
- Comply with API 608.



NOTE: This drawing is only for reference.

Material List⁽¹⁾

POS	DESCRIPTION	MATERIAL
1	BODY	ASTM A105
2	BONNET	ASTM A105
3	BALL	ASTM A182 F316
4	SEAT RING	R-PTFE
5	THRUST WASHER	PTFE
6	STEM	ASTM A182 F316
7	STEM O-RING	VITON
8	PACKING	GRAPHITE
9	GLAND	SS316
10	POSITIONING PIN	SS316
11	POSITIONING PLATE	SS316
12	LEVER	201 + PLASTIC
13	STEM NUT	SS316
14	BODY GASKET	GRAPHITE + SS316
15	BODY O-RING	VITON
16	BELLEVILLE WASHER	SS316

NOTES:

(1) Material List example for Fire Safe version.

- Seat Material options: RPTFE & PEEK (Other seats available).
- Internal Material options: Stainless Steel ASTM A182 Gr. 304/304L/316L/F51; Alloy Steel ASTM A182 Gr. F6a.
- Body Material options: Forged Steel ASTM A105, ASTM A350 Gr. LF2; Stainless Steel ASTM A182 Gr. F304L / F316L / F51.



Dimensions

<i>NPS</i> (in)	<i>L</i> (mm)	<i>d</i> (mm)	<i>W</i> (mm)	<i>H</i> (mm)	<i>NPT</i> (in)	<i>Weight</i> (kg)	<i>CV</i> (USgal/min)	<i>Open Torque</i> (Nm)
1/2"	85.00	14.00	135.00	62.00	1/2"	1.40	3.03	25.00
3/4"	105.00	19.00	165.00	80.00	3/4"	2.50	7.07	35.00
1"	115.00	25.00	220.00	93.00	1"	3.50	12.25	70.00
1 1/4"	130.00	31.00	220.00	98.00	1 1/4"	4.80	20.26	100.00
1 1/2"	145.00	38.00	255.00	106.00	1 1/2"	6.80	28.30	138.00
2"	160.00	48.00	305.500	120.00	2"	10.30	47.05	200.00
-	-	-	-	-	-	-	-	-

Pressure-Temperature Chart

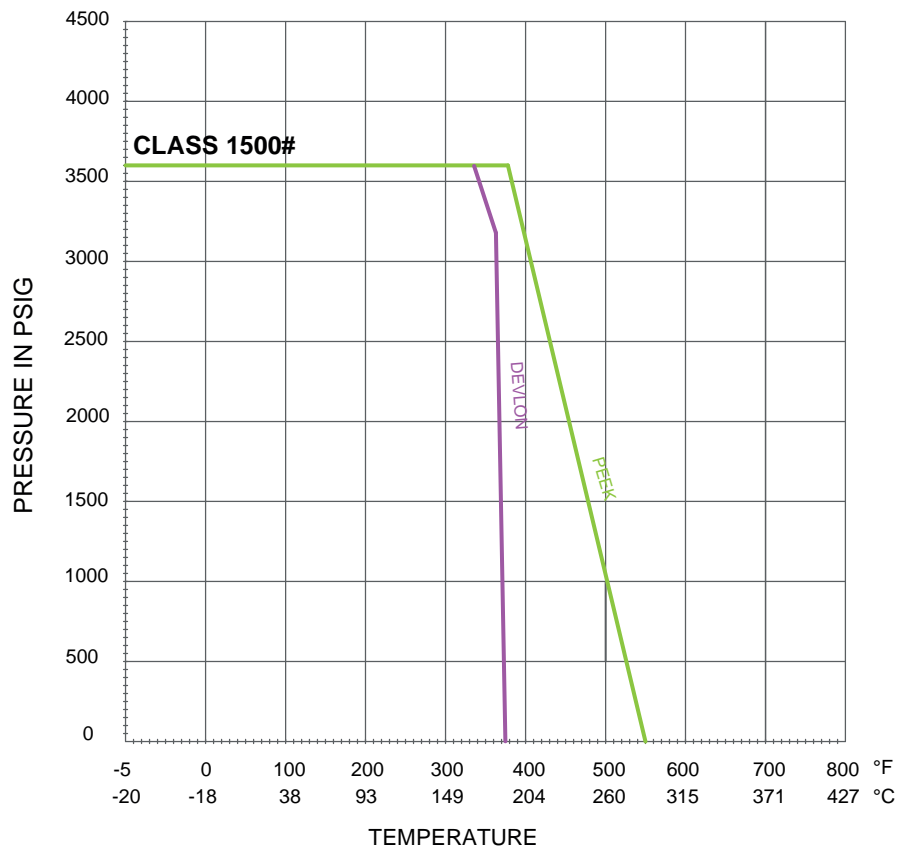

How to Order

BODY DESIGN (SERIES)	FEATURES	MATERIAL			ENDS	CLASS	SIZE		OPERATION
		BODY	TRIM	SEAT					
152W ANSI 1500# (seal welded body)	F Fire Safe	2 A105	3 316 SS	R RPTFE	T Threaded	1 ANSI 1500#	0.5	1/2"	L Manual Lever Operator
	N NACE	3 316 SS	4 304 SS	K PEEK	S Socketweld		0.75	3/4"	C Manual Lever Operator with Locking Device
	G Fire Safe & NACE	4 304 SS	5 316L SS	N NYLON	F Flanged ⁽¹⁾		01	1"	
		5 316L SS	7 304L SS				01.5	1 1/2"	
		7 304L SS	8 F6a				02	2"	
		8 LF2	9 F51 Duplex						
		9 F51 Duplex							

Example:

Forged Steel Ball Valve, Seal Welded Design, Fire Safe API 607, Body A105 + 316 SS Trim, Seat RPTFE, Threaded ANSI Class 1500#, Size 2" Ø, Manual Lever Operator.

152WF23RT802L

(1) Flanged valves options are flange welded (not integral body).
Please contact us for more information about sizes and ratings allowed.

