

Features / Design

Forged Ball Valves / Bolted Body - 153 Series

- Full Port minimizes pressure drop and prolongs life.
- Forged Steel body construction (three pieces design).
- Bolted body option.
- Threaded NPT Ends ANSI B1.20.1.
- Socket Weld Ends ANSI B16.11 option available.
- ANSI Class 1500#.
- Manufactured in ISO 9001 approved facility.
- Design according API 608, ANSI/ASME B16.34.
- Fire Safe API 607 (upon request).
- Hydrostatic Tests according API 598 & API 6D.
- NACE MR0175 (upon request).
- Comply with API 608.

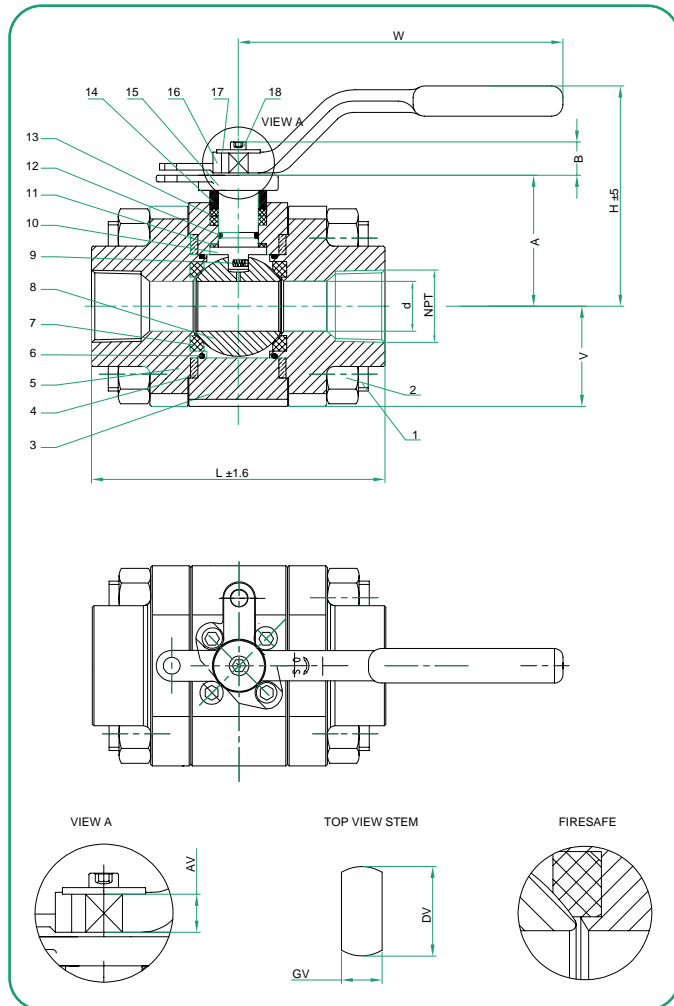

NOTE: THIS DRAWING IS ONLY OF REFERENCE.

Material List

POS	DESCRIPTION	MATERIAL
1	HEX. BOLT	ASTM A193 B7M
2	HEX. NUT	ASTM A194 2HM
3	BODY	ASTM A105N
4	GASKET	SS304 + GRAPHITE
5	BONNET	ASTM A105N
6	O-RING	VITON
7	SEAT	R-PTFE
8	BALL	ASTM A182 F316
9	ANTISTATIC SPRING	SS 304
10	STEM	17-4PH
11	THRUST PAD	R-PTFE
12	O-RING	VITON
13	PACKING	GRAPHITE
14	GLAND	ASTM A276 316
15	GLAND FLANGE	ASTM A216 WCB
16	HANDLE	ASTM A216 WCB
17	FLAT PAD	CARBON STEEL
18	SOCKET HEAD BOLTS	ASTM A193 B8

NOTES:

1. Seat Material options: RPTFE & PEEK (Other seats available).
2. Internal Material options: Stainless Steel ASTM A182 Gr. 304/304L/316L/F51; Alloy Steel ASTM A182 Gr. F6a.
3. Body Material options: Forged Steel ASTM A105, ASTM A350 Gr. LF2; Stainless Steel ASTM A182 Gr. F304L / F316L / F51.



Dimensions

NPS (in)	L (mm)	d (mm)	A (mm)	B (mm)	W (mm)	H (mm)	DV (mm)	GV (mm)	AV (mm)	V (mm)	NPS (in)	Weight (kg)	CV (USgal/min)	Open Torque (Nm)	Close Torque (Nm)
1/2"	100.0	13.0	45.0	14.0	180.0	85.0	10.0	7.0	7.0	30.0	1/2"	1.9	17.0	25.0	20.0
3/4"	113.0	19.0	53.0	17.0	210.0	95.0	14.0	9.0	9.0	35.0	3/4"	3.0	37.0	35.0	28.0
1"	128.0	25.0	60.0	20.0	272.0	116.0	18.0	12.0	11.0	40.0	1"	4.6	65.0	50.0	40.0
1 1/2"	156.0	38.0	82.0	25.0	303.0	131.0	22.0	16.0	14.0	53.0	1 1/2"	9.5	149.0	75.0	62.0
2"	172.0	51.0	85.0	27.0	330.0	150.0	22.0	16.0	15.0	63.0	2"	13.0	269.0	110.0	88.0
-	-	-	-	-	-	-	-	-	-	-	-	-	-	-	-
-	-	-	-	-	-	-	-	-	-	-	-	-	-	-	-

Pressure-Temperature Chart

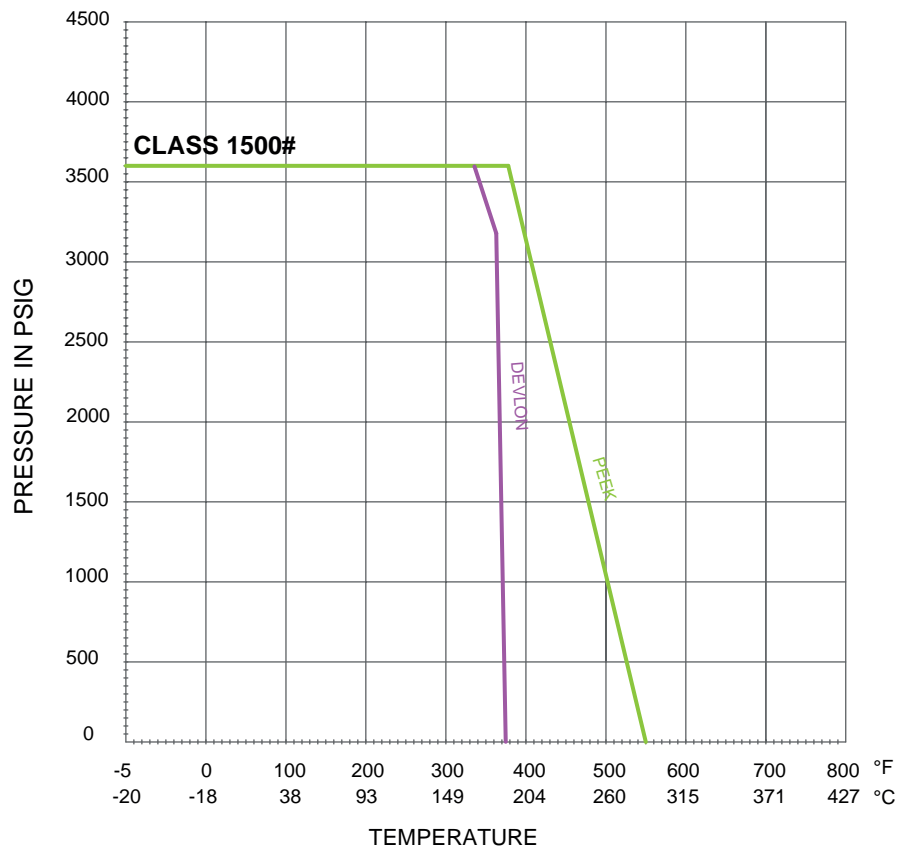

How to Order

BODY DESIGN (SERIES)	FEATURES	MATERIAL			ENDS	CLASS	SIZE		OPERATION
		BODY	TRIM	SEAT					
153 ANSI 1500# (3t-pieces bolted body)	F Fire Safe	2 A105	3 316 SS	R RPTFE	T Threaded	1 ANSI 1500#	0.5	1/2"	L Manual Lever Operator
	N NACE	3 316 SS	4 304 SS	K PEEK	S Socketweld		0.75	3/4"	C Manual Lever Operator with Locking Device
	G Fire Safe & NACE	4 304 SS	5 316L SS	N NYLON	F Flanged ⁽¹⁾		01	1"	
		5 316L SS	7 304L SS				01.5	1 1/2"	
		7 304L SS	8 F6a				02	2"	
		8 LF2	9 F51 Duplex						
		9 F51 Duplex							

Example:

Forged Steel Ball Valve, 3 Pcs. design, Fire Safe API 607, Body A105 + 316 SS Trim, Seat RPTFE, Threaded ANSI Class 1500#, Size 2" Ø, Manual Lever Operator.

153F23RT102L

(1) Flanged valves options are flange welded (not integral body).
Please contact us for more information about sizes and ratings allowed.

